



Maestro Industrial



Instruction Manual Rev. 1.4

Rev / date	Modified by	Comment
1.4 / 23 Feb. 09	Pierre-Emmanuel Sarga	Added figure for wiring of DC power supply

1 INTRODUCTION

1.1 Background

This manual serves as a reference for users of the Maestro Industrial. The Maestro Industrial is a GSM/GPRS device used in applications where data must be returned from some or another remote device with a serial port.

The Maestro Industrial is capable of both translating between a serial communications and GPRS and acting like a standard AT-driven GSM modem. Four digital inputs can be programmed with a large number of commands to perform some or another action when triggered.

1.2 Scope of This Manual

The following aspects of the Maestro Industrial are covered:

- Features
- Power Supply
- Mounting
- Interfaces
- Events Programming
- AT Programming

2 MAESTRO INDUSTRIAL

2.1 A Modem and Telemetry Device in One

The Maestro Industrial is a GSM/GPRS terminal intended to be used in industrial telemetry applications. Even though the Maestro Industrial can act like a GSM modem, it offers much more in terms of communications, inputs, and event-based programming.

By using simple commands, the Maestro Industrial can switch between using CSD (circuit switched data) calls, or GPRS to communicate with a device on the serial port. Four fully programmable inputs, timers, counters and other events provide a very powerful and future-proof solution for industrial communications.

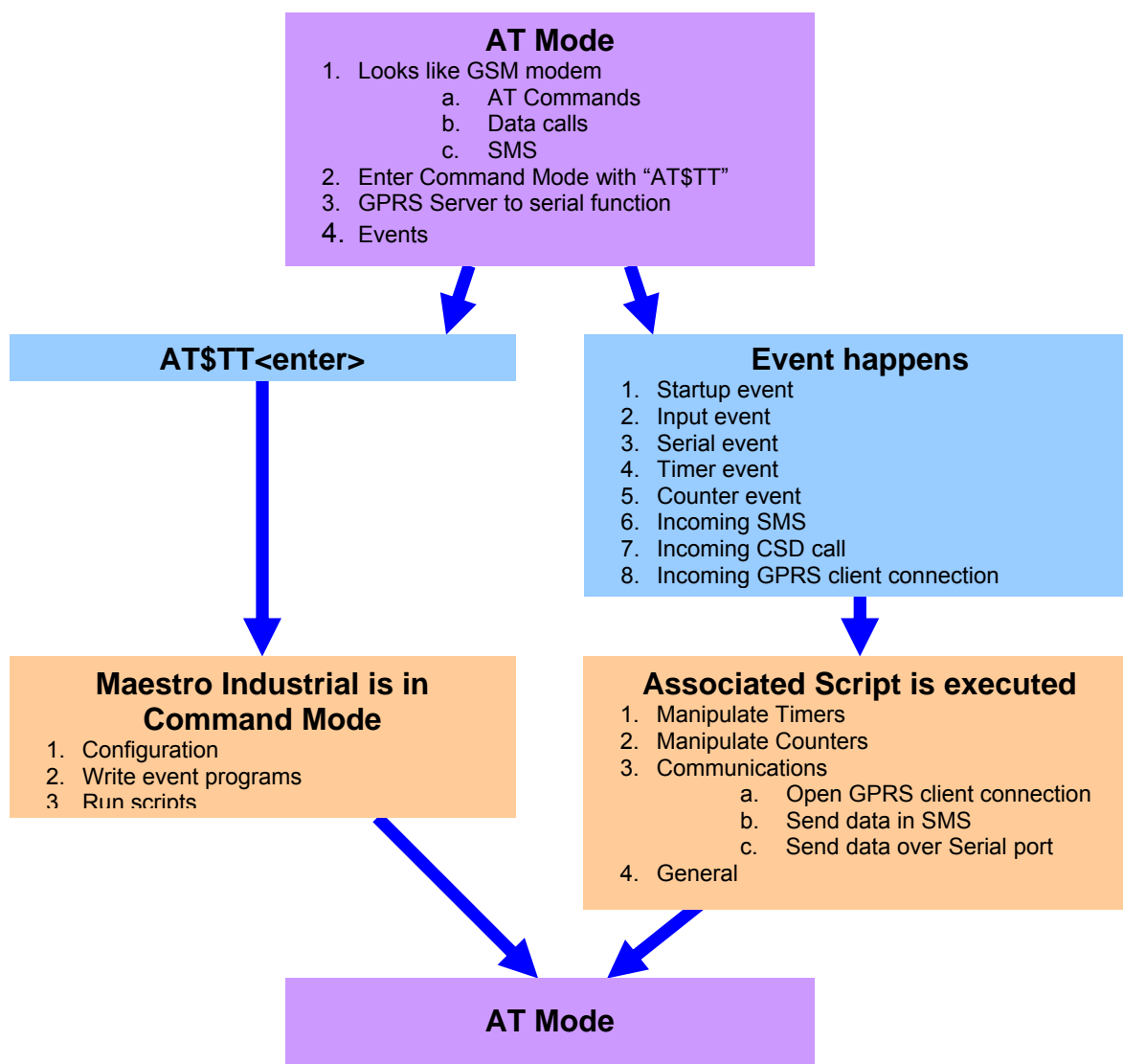

The Maestro Industrial operates in the following modes:

1. AT Mode
2. Command Mode

In AT Mode, the Maestro Industrial accepts normal AT commands like a GSM/GPRS modem. In this mode, events (such as inputs) will trigger the program scripts associated with them.

Command Mode is used to access the telemetry features and to program the scripts associated with events.

The Maestro Industrial will not remain in Command Mode and will automatically revert back to AT Mode after some time of inactivity.

2.2 The Ports

The Maestro Industrial has two ports available in a number of configurations:

- 1) Primary data port
- 2) Secondary data port
- 3) Auxiliary port

The different combinations of these ports are possible with the appropriate internal daughterboard option. Not all the ports may be accessible in all the configurations. In the simplest configuration, the Maestro Industrial will have a DB9 female on the primary data port, and an RJ45 with four inputs on the auxiliary port.

The data ports support asynchronous communications. Full handshaking is only available on the Primary data port on the DB9 connector. The primary port does not support MARK or SPACE parity and is limited to a maximum of 57600 baud.

The primary data port and the secondary data port work independently from each other and may have different character framing and baud rates.

The auxiliary port is used as a as a telemetry port with four digital inputs.

Port Options

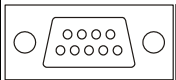
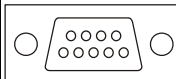
Option	Primary Data Port		Secondary Data Port		Auxilliary Port		Side View
	Connector	Interface	Connector	Interface	Connector	Interface	
1	DB9	RS232			RJ45	4 x Inputs	
2	DB9	RS232	Terminal	RS485			

Pinouts

All the pinouts are looking into the connector on the modem with the antenna connector pointing right.

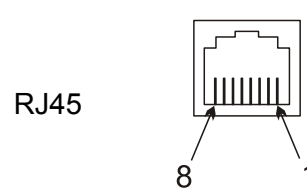
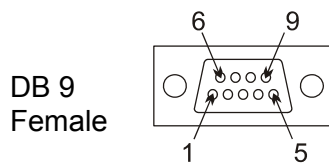

2.3 The Primary Data Port

The Primary Data Port is available under all the port options. The pinouts are as follows:

Symbol	Function	Input/Output	DB9
DCD	Data Carrier Detect	Output	1
RX	Receive data	Output	2
TX	Data Transmit	Input	3
DTR	Data Terminal Ready	Input	4
GND	Ground	Input	5
DSR	Data Set Ready	Output	6
RTS	Ready to Send	Input	7
CTS	Clear to Send	Output	8
RI	Ring Indicator	Output	9

2.4 The Secondary Data Port

The pinouts are as follows :

Symbol	Function	Terminal
A	RS485+	A
B	RS485-	B

2.5 The Auxilliary Port

The pinouts are as follows :

Symbol	Function	RJ45
NC	Do not connect	1
Input 1	Input 1 – Short to pin 8 to trigger	2
Input 2	Input 2 – Short to pin 8 to trigger	3
NC	Do not connect	4
Input 3	Input 3 – Short to pin 8 to trigger	5
Input 4	Input 4 – Short to pin 8 to trigger	6
NC	Do not connect	7
Common	Inputs common	8

3 FEATURES

3.1 The Ultimate in Stability – Comm Alive!

Telemetry users know that their devices are often in remote or inaccessible areas. The last thing they can afford is to have to continuously visit a number site to reset these devices.

There are four major causes of failures in GSM-based telemetry:

1. Lockups between modem and GSM network.
2. Unterminated data calls.
3. Loss of network authentication.
4. Unknown network or modem status.

By using proven and patented technology, the Maestro Industrial is kept as stable as possible. **Depending on the customer's preferences on order, the modem will reset under any of the following conditions:**

1. Every 24 hours (only if not in data call).
2. If a data call is unterminated for longer than 1 hour.
3. If the modem loses GSM network authentication for longer than 10 minutes.

If the modem is in a data call when the 24hr reset cycle starts, the modem will wait for 10 minutes before resetting.

The default reset options are:

1. Every 24 hours (only if not in data call).
2. If the modem loses GSM network registration for longer than 10 minutes.

3.2 LED Display

A display of ten LEDs offers a powerful troubleshooting and verification function:

LED	Meaning	States
Power	Power present	Off : Not powered On : Powered
GSM Network	GSM Network state	On solid : Searching Short Flash : Logged on network Long Flash : Busy in data call
TX	Transmit	On : Meter transmits data
RX	Receive	On : Meter receives data
DTR	Data Terminal Ready	On : Meter ready
DSR	Data Set Ready	On : Modem ready
RTS	Request to Send	On : Meter ready to transmit data
CTS	Clear to send	On : Modem ready to accept data
RI	Ring Indicator	Flash : Ring - waiting to answer
DCD	Data Carrier Detect	On : Busy in data call

3.3 LED Time delays on RX and TX

At 9600 baud, the bit lengths are only $104\mu\text{s}$ (0.000104s) long, and virtually impossible to see with the human eye. To enable the user to be able to see when the meter transmits and received data, short delay of around 200ms (0.2s) have been added to the RX and TX LEDs. These delays do not interfere with the communication in any way and only affect the time that the respective LEDs are lit.

4 POWER SUPPLY

4.1 AC Mains Supply

The Maestro Industrial may be powered from 90VAC to 265VAC. The mains supply is connected to the terminal block as shown in the following picture:



Important Notices

Make sure the mains power line supplying the Maestro Industrial is protected by a Fuse or a Circuit Breaker which is in accordance to the local codes and regulations

The Maestro Industrial must operate with an earth connection

The Maestro Industrial is a built-in equipment and designed for installation inside an enclosure (eg. instrumentation panel) by qualified installers. All high-voltage connections such as the power supply terminal block must be housed in the enclosure to protect human bodies from electric shock.

Installers to take all relevant safety precautions:

- **All wirings must be completed before power is turned on**
- **The power must be turned off before repairing work for input break**
- **Do not touch high-voltage connections such as the power supply terminal block**

4.2 DC Supply

An optional DC Supply Cable allows the integrator to configure the Maestro Industrial in such a way that a backup battery can keep the modem alive after loss of mains supply.

If the DC supply is used in conjunction with the mains supply as a DC back-up, then the backup supply to the Maestro Industrial should go through an external non-return diode.

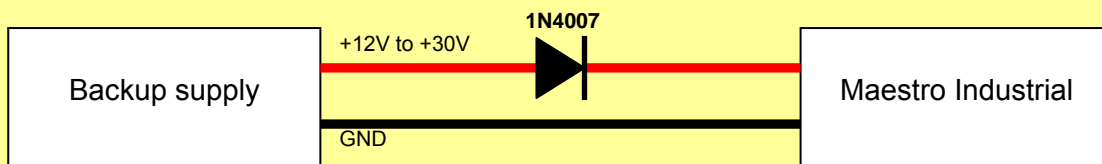

This diode is not required when the DC supply is used without the mains supply.

The pin arrangement of the internal DC connector (white plug) is as follows:

Option 1

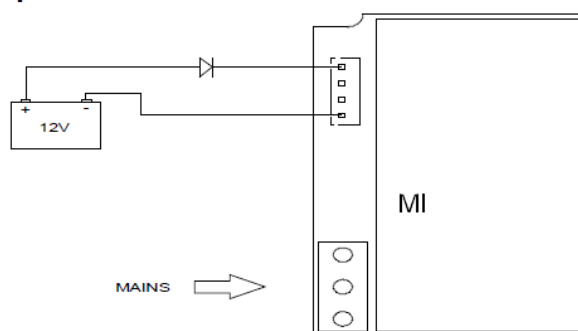

Option 2

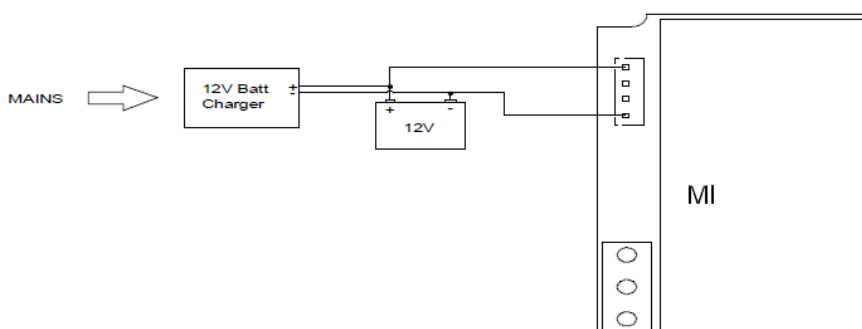

A standard built-in hysteresis protects the Maestro Industrial in cases where it is supplied from a DC source and the backup supply voltage drops to a point where it becomes unsafe to operate (under 9.5VDC). It will hold the Maestro Industrial in reset until the voltage increases to above 10VDC again.

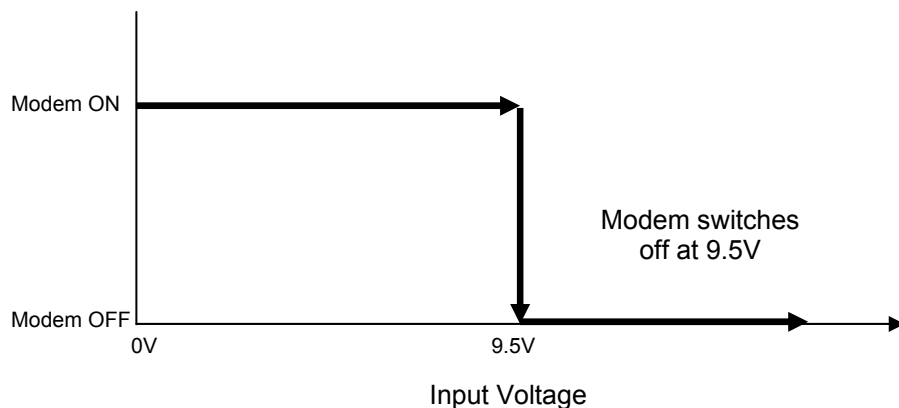
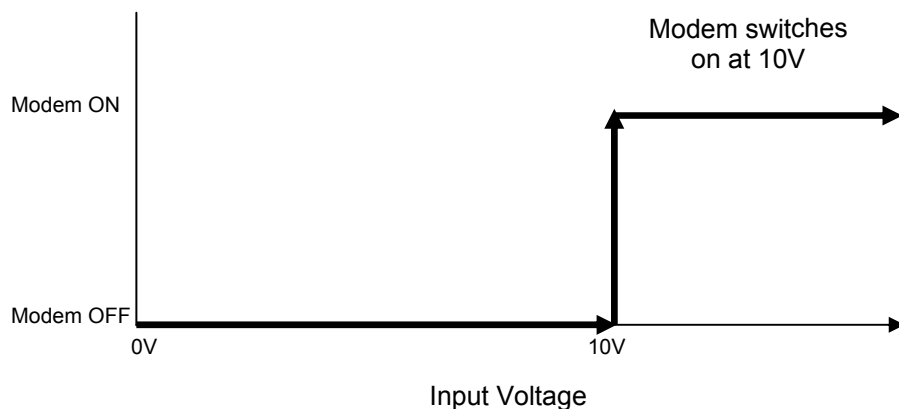

The hysteresis also protects the modem in cases of mains brown-out.

Please note that the DC backup supply must be capable of supplying at least 12VA. This means that, at 12V, the supply must be able to supply 1A. This is not the continuous current that the Maestro Industrial requires, but the pulses required when the modem is in communication during a download. If the voltage drops to below 9.5V on current peaks, the modem will reset and drop any open data calls.

5 INTERFACES

The antenna interface

Most GSM modems use the low-cost FME connector. The SMA connector used on the Maestro Industrial is superior with lower losses. This means you can get to areas where other modems will fail.

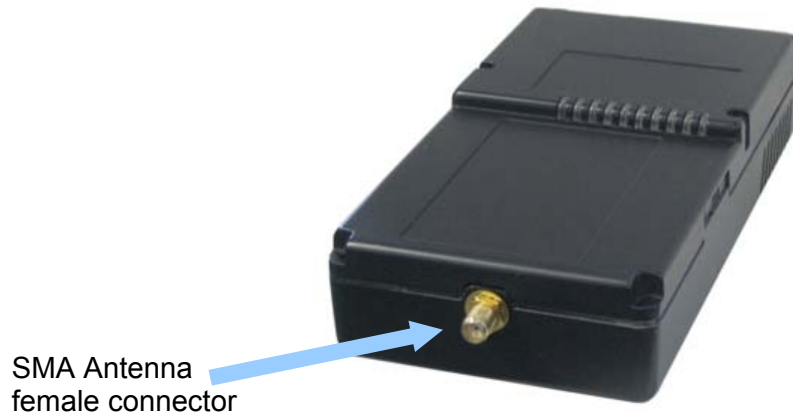

5.1 SIM card interface

The SIM card holder takes a standard SIM card. The Maestro Industrial is available in a version with a side-entry SIM card holder as well as tamper-resistant version.



6 EVENTS

An event is a change in condition and where certain commands then need to be executed.

6.1 Startup event

On startup, the Maestro Industrial performs a startup script.

6.2 Digital Input events

Separate scripts are linked to the events where an input goes high (on/open) or low (off/closed). The delay times (also known as the “debounce” times) before the unit registers a change in input state can be configured. More input/output boards can be added to increase the total number of inputs and outputs.

6.3 Timer events

Separate scripts are linked to the events where a timer runs out. There are 5 separate timers.

6.4 Counter events

Separate scripts are linked to the events where a counter reaches one of its low or high levels. There are 4 different counters, each with its own high and low levels.

6.5 Serial events

The Maestro Industrial can be configured to execute certain commands when data is received on the serial port. Typical applications are tag readers and barcode scanners as well as a whole list of devices that sends out unsolicited serial data.

7 STARTING UP

7.1 Powering up the Maestro Industrial

7.1.1 *Using Mains Supply*

1. Switch off or disconnect mains supply
2. Insert SIM card
3. Connect data or auxiliary ports
4. Connect mains power to Maestro Industrial
5. Reconnect mains supply

7.1.2 *Using DC Supply*

1. If connected to a DC supply, switch the supply off or disconnect the DC cable
2. Insert SIM card
3. Connect data or auxiliary ports
4. Connect or power up DC supply

8 CONFIGURING THE DEVICE

All commands are typed in the terminal window of an application such as Windows HyperTerminal or preferably with YAT program. Contact Maestro Wireless Solutions for YAT program.

Start off with a test to see if the communications settings are the same between the modem and the terminal window. If these settings are not the same, you will not be able to communicate properly.

Type in "AT" and ENTER

The modem should respond with "OK". If it does not respond with "OK", then there is a problem. Refer to the Trouble Shooting section further in the document.

It is important that communication with the modem is established before continuing.

Close the COM port (some terminal programs may call this "disconnect") and change the communication speed of the software to 9600 baud. This is necessary in order to be able to talk to the modem, which will now be set to 9600 baud. Open the COM port again.

Check if a PIN number is required for the SIM card

Type in the command:

AT+CPIN?

If the response is:

+CPIN: READY

carry on to the next section

If the response was:

+CPIN: SIM PIN

the Modem requires a PIN number first. Issue the PIN number as follows:

AT+CPIN=00000

For the default PIN number of 00000. If the PIN number is different, use the number you received with the SIM card. You should now get the response:

OK

Disable the PIN with the following command:

AT+CLCK="SC",0,00000

Where the 00000 is the default PIN number. Use the supplied PIN number if different from 00000. The response should be:

OK

Important: If you type in the wrong PIN number three times, you will have to unblock the card using the PUK number. The easiest way is to use your cell phone to unblock the SIM.

Check if the modem is registered on the GSM network

Type in the command:

AT+CREG?

If the response is :

+CREG: 0,1

carry on to the next section

Other possible responses could be:

- +CREG: 0,0 – Searching for any network
- +CREG: 0,2 – Network found, busy registering
- +CREG: 0,5 – Registered on a roaming network

If the response is 0,0 or 0,2, then wait a while for the modem to register. Try the command again until registered.

If the 0,5 response was received, then the modem is registered on a foreign GSM network. This could happen close to international border. There may be substantial financial implications if communication takes place through a foreign network, even if the modem only receives the calls.

Check the signal strength

Type in the command:

AT+CSQ

The response should be at least

+CSQ: 10,0

the 10 indicates signal strength and this result value should be better than 10. The 0 result value is an indication of the bit error rate on the radio interface, and should be a value from 0 to 7. If this value is 99, it means that the modem has not been able to resolve the error rate.

The modem performs automatic error correction on the radio interface, so the bit error rate is not a critical value and can be ignored. The important result value is the signal strength.

Set the automatic answer

Type in the command:

ATSO=2

The response should be:

OK

Set the incoming bearer type

Type in the command:

AT+CICB=0

The response should be :

OK

Save the settings

Type in the command:

AT&W

The response should be

OK

9 TELEMETRY WITH THE MAESTRO INDUSTRIAL

Please see document TruTalk for the latest available telemetry options.

10 TROUBLESHOOTING

10.1 No LEDs come on

Check if the voltage selector switch is in the appropriate position for the supply. Test the supply with an appropriate meter. The values should be close to 115VAC for the 115VAC setting, close to 230VAC for the 230VAC setting, and between 10VDC and 30VDC if the DC backup supply is used (optional).

If the measured voltages are all within range, the modem may be faulty.

10.2 Power LED, and CTS LED come on, but the GSM LED won't flash

If the GSM LED does not start flashing after 10 or 20 seconds, the modem cannot register.

This could mean that the GSM coverage is not adequate (try better antenna positions), that there is a PIN number required for the SIM card (remove it using the method described), or that the SIM card is blocked by the GSM network, or even faulty (replace the SIM card).

10.3 I get an "OK" for an AT<13> request, but I can't program the modem.

You may be communication with another modem inside your computer. A normal fixed line modem will respond almost the same as the Maestro Industrial, but will give errors when certain (GSM specific) commands are given to it.

Try looking for the GSM device on another COM port.

10.4 Calls are frequently dropped

This is usually due to either a poor signal strength, or to a backup supply with insufficient driving capacity when running from backup DC supply.

To test, check the signal strength as follows:

Type in the command:

AT+CSQ

The response should be at least:

+CSQ: 10,0

the 10 indicates signal strength and this result value should be better than 10. The 0 result value is an indication of the bit error rate on the radio interface, and should be a value from 0 to 7. If this value is 99, it means that the modem has not been able to resolve the error rate.

If the signal strength is lower than 10, try relocating the antenna to a higher position. If you are using a magnetic mounting antenna, try mounting the antenna on a metal plate. A high gain antenna like a yagi may also solve the problem.

If the Maestro Industrial is running from a DC Backup supply and signal strength is high, check the supply capacity as follows:

1. Disconnect the modem from the Backup supply.
2. Connect 8 x 100Ω (5W wirewound) in parallel to create a resistor array for a dummy load.
3. Connect the dummy load to cables at least 1m long each.
4. Connect the cables to the output of the Backup supply and measure the voltage across the terminals at the dummy load.
5. Disconnect the cables immediately after measurement.
6. Take extreme caution as the dummy load will become hot enough to cause 3rd degree burns or start a fire if left unattended.

The voltage measured across the dummy load should be 12V or higher.

11 GLOSSARY

Abbreviation	Description
2G	2nd Generation of Mobile phone technology. In developed and in some developing economies the current state of digital mobile communications development is 2.5G
2.5G	Usually refers to GPRS or EDGE technology. Mid-way point on path to true 3rd generation mobile communications. Enables WAP communication and some low-speed (compared to fixed line) data transfer.
3G	3rd Generation mobile communications. The long-awaited generation of mobile comms development, incorporating broadband wireless access to data services. This enables new applications such as mobile entertainment and expanded types of mobile business.
ASCII	American Standard Code for Information Interchange
Bit	Binary digit: the smallest unit of data
BS	Base Station
BSC	Base Station Controller
BTS	Base Transceiver Station
Byte	Eight Bits that represent one character
Calling Line	System that identifies the Calling line to the device ID (CLI) being called
Carrier	Company that provides public or private communication networks
CDR	Call Detail Record. Basis of telecoms billing
Cells	Basic areas that make up cellular networks.
Circuit	Physical path of channels between two points that carry a current - the telephone call
CSD	Circuit switched data
CLI	Calling Line Identification
CPU	Co- Processor Unit
CSD	Circuit Switched Data
DTMF	Dual Tone Multi Function touch-tone dialling
ETSI	European Telecommunications Standards Institute www.etsi.fr
Fax	Telecoms system that allows a hard copy of a document to be sent and received over analogue or digital telephone lines
GMSC	Gateway Mobile Services Switching Centre
GPRS	General Packet Radio System

GSM	Global System for Mobile communications: The most commonly used standard for digital mobile communications
IMSI	International Mobile Subscriber Identity
IP	Internet Protocol: Protocols for software that tracks Internet addresses
MS	Mobile Station
MSISDN	Mobile International Subscriber Directory Number
Operators	Telecoms network operators
OS	A computer's Operating System
PABX	Private Branch Exchange: a private telephone switch that sits on the user's premises and switches calls to extensions
POTS	Plain old telephone services
PSTN	Public Switched Telephone Network
QoS	Quality of Service
SMS	Short Message Service
SMSC	Short Message Service Centre
USSD	Unstructured Supplementary Service Data signalling
WAP	Wireless Application Protocol. Mobile comms standard for Internet connection

12 REVISION INFORMATION

Date	Version	Comments	Author
2 August 2005	0.1	Creation	Tjaart van der Walt
29 September 2005	1.0	Work in progress.	Tjaart van der Walt

13 DISCLAIMER

Maestro Wireless Solutions does not accept any direct or indirect liability for the use of any Maestro Wireless Solutions product. The customer takes full responsibility for its use and any liability or damage that may arise from the use of the Maestro Wireless Solutions product.

NOTE: This product is **not designed or certified** for use as medical equipment or with medical equipment or with medical devices. This product is also **not designed or certified** to be used with any medical services or medical related services.