

mikroPascal for AVR



Creating First Project in mikroPascal for AVR

In this simple tutorial, we will create a new project, write some code and compile it in mikroPascal for AVR and test the results. Our project will make LED diodes blink, so it can be easily tested on AVR microcontrollers.

Creating first project in mikroPascal for AVR

Hardware Connection

Here is the connection scheme you'll need to test the code for microcontroller. We have used common chip in our examples, but you may use any other microcontroller. LED diodes are connected to PORTB, but you can use any other available port – you would need to replace few lines in the code, as explained in the following pages.

AVR MCU
(ATmega8535)

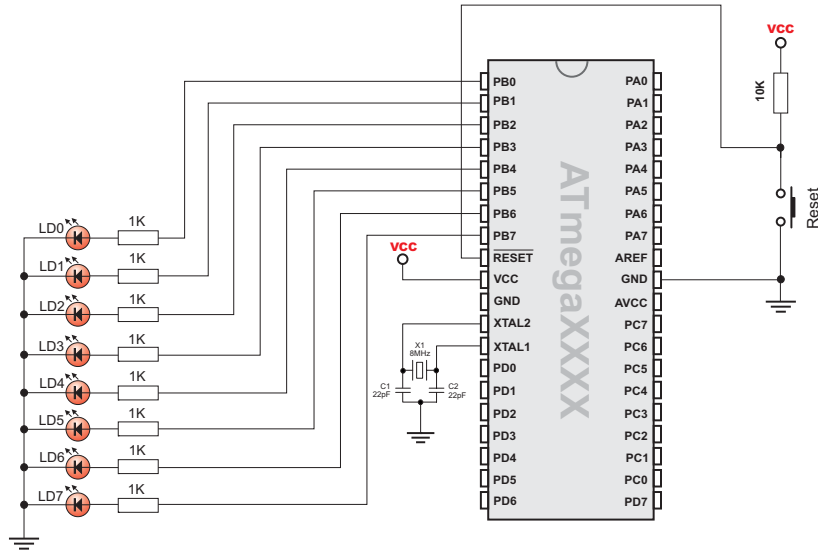

Step 1: Install the compiler

Install the mikroPascal for AVR compiler. Desktop shortcut and start menu shortcuts will be created.

Step 2: Run the compiler

Run the mikroPascal for AVR compiler. mikroPascal IDE (Integrated Development Environment) will appear.

Step 3: Start the Wizard

Click the New Project icon or select **Project > New Project** from the drop-down menu:



New Project.

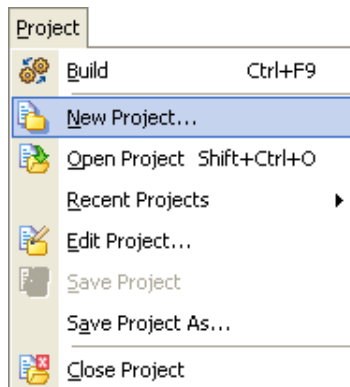

Creating first project in mikroPascal for AVR

Step 4: Set up your project

Project Wizard dialog will appear - fill the dialog with appropriate settings for your project:

- Enter a name for your new project,
- Choose project path,
- Enter short text which describes your project (this is optional),
- Choose the microcontroller from drop-down menu (we have chosen the one that is used in schematic for selected microcontroller, you may select any other),
- Set the device clock by entering the value in edit box (we have set the same value as drawn in schematic),
- After you have set up your project, click OK to continue.

New Project window for mikroPascal for AVR

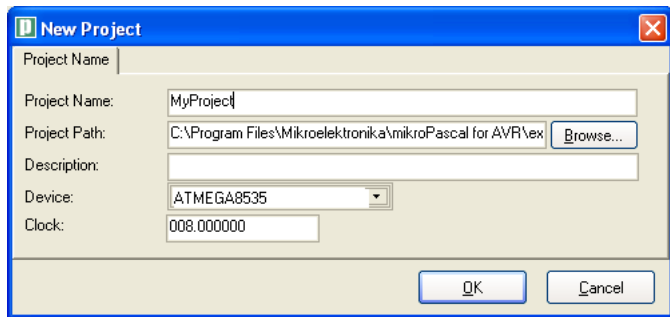

Step 5: Write the code

Compiler will create the project file and an accompanying source file, named same as your project. This source file will be automatically opened in the Code Editor, so we can write the source code. This is the Code Editor:

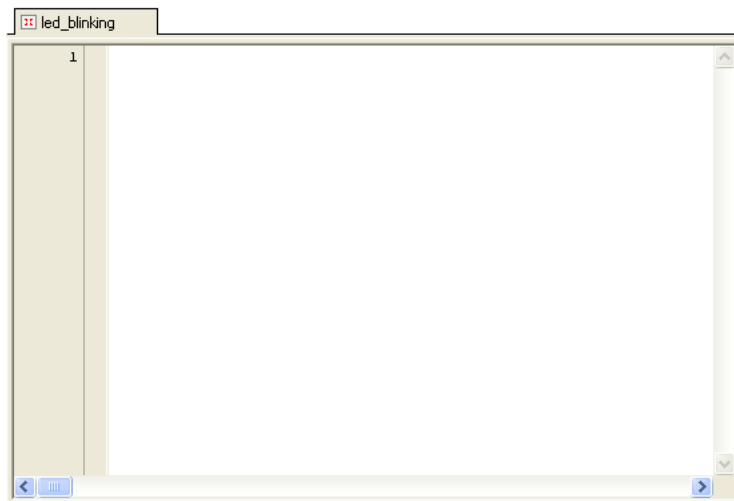

Creating first project in mikroPascal for AVR

Led blinking for mikroPascal for AVR:

Here is the code that will make LED's on PORTB blink every second. Type it in the Code Editor (if there is any default code you can over write it):

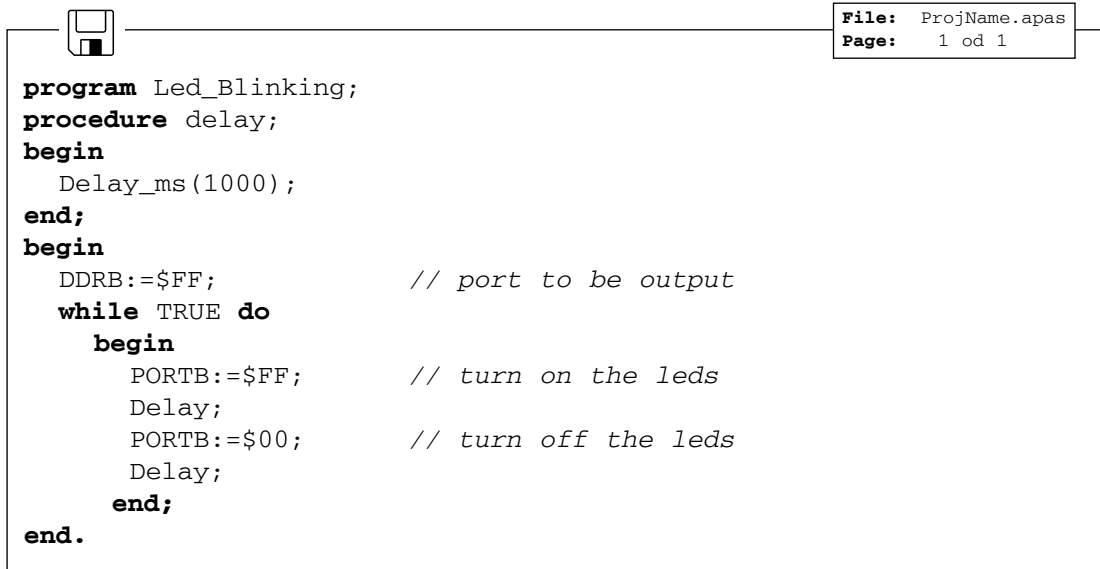

```
program Led_Blinking;
procedure delay;
begin
    Delay_ms(1000);
end;
begin
    DDRB:=$FF;           // port to be output
    while TRUE do
        begin
            PORTB:=$FF;   // turn on the leds
            Delay;
            PORTB:=$00;   // turn off the leds
            Delay;
        end;
    end;
end.
```

Note: If you want to try another port, just replace each instance of PORTB and DDRB in code with your port, e.g. PORTC/DDRC.

Step 6: Build!



Build.

Now it's time to build our project. First, save your file by clicking on the Save Icon, or click Ctrl+S. Select **Project > Build** from the drop-down menu, or click the Build Icon. You can also use the shortcut Ctrl+F9.

Compiler will generate output files in the project folder. There should be 4 new files: ProjectName.asm, ProjectName.lst, ProjectName.mcl, and ProjectName.hex. The last one will be used to program the microcontroller directly.

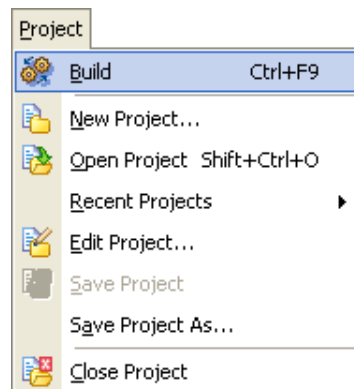

Step 7: Real World test

To "burn" the AVR you can use the compiler's integrated (AVRprog) programmer (default shortcut is F11) or any other programmer for selected microcontroller. As a result, LED's connected to PORTB of programmed microcontroller should blink indefinitely.