



Features

- Low-power 3.3V CMOS design
- Compatible to PL2303X
- On board 5V to 3.3V voltage regulator
- Single 6 / 12 MHz crystal
- Supports Data rates from 75 bps to 6 Mbps
- External RS232 transceiver shut down
- USB specification 1.1 compliant.
- Re-configurable Vendor specific parameters (Vendor ID, Product ID, Release #)
- Support for 4 string descriptors (Language ID, Manufacture ID, Product Name, Serial Number)
- Supports remote wakeup and power management features
- I2C interface for EEPROM
- Low-profile 28-Pin SSOP package

Applications

- Cell Phones
- Embedded applications

Application Note

- AN7703

Evaluation Board

- MCS7703-EVB

General Description

The MCS7703 controller provides bridging between the Universal Serial Bus (USB) input and an enhanced UART port. This device contains all the necessary logic to communicate with the host computer via the USB bus.

In addition, the MCS7703 contains a 3.3V regulator and operates in bus-powered mode.

The MCS7703 uses single 12 MHz crystal oscillator. This combination of features allows significant cost savings in system design along with straightforward implementation of serial port functionality into PC peripherals using the host's USB port.

Commercial Grade

MCS7703CS	28-SSOP	0° C to +70° C
-----------	---------	----------------

MCS7703

USB 1.1 to Serial Port



MCS7703 Block Diagram

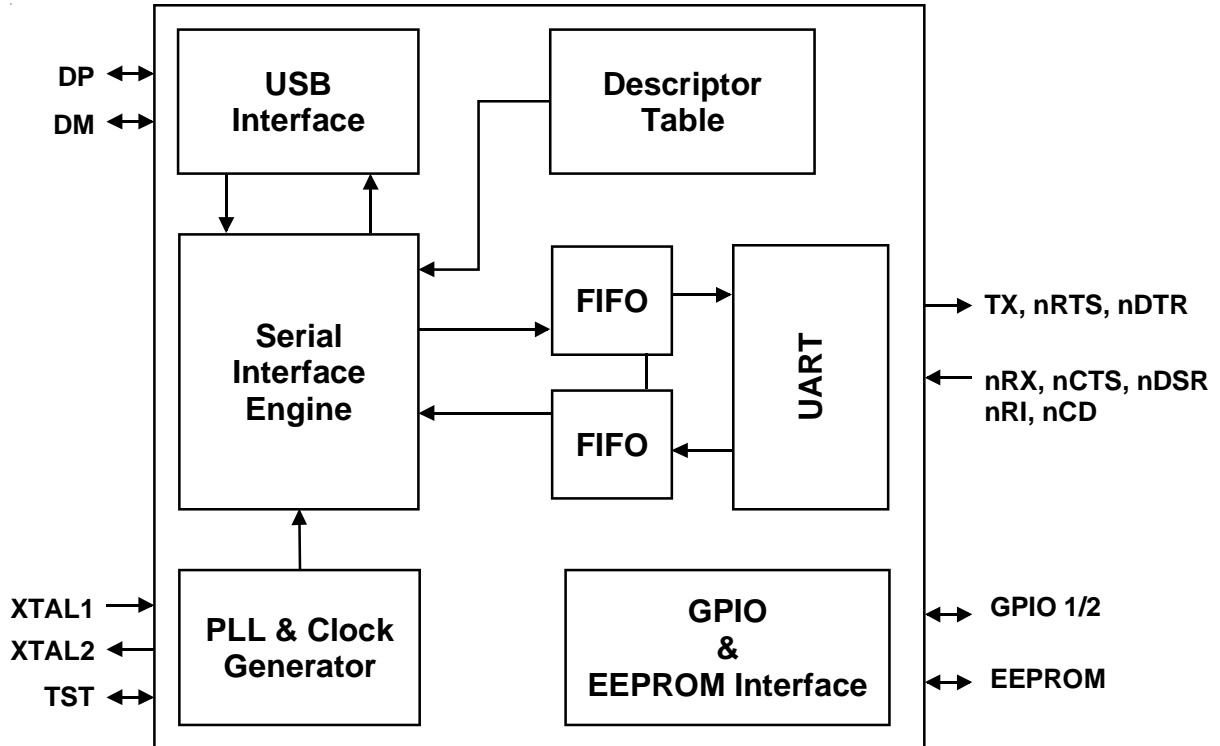



28-Pin SSOP Package

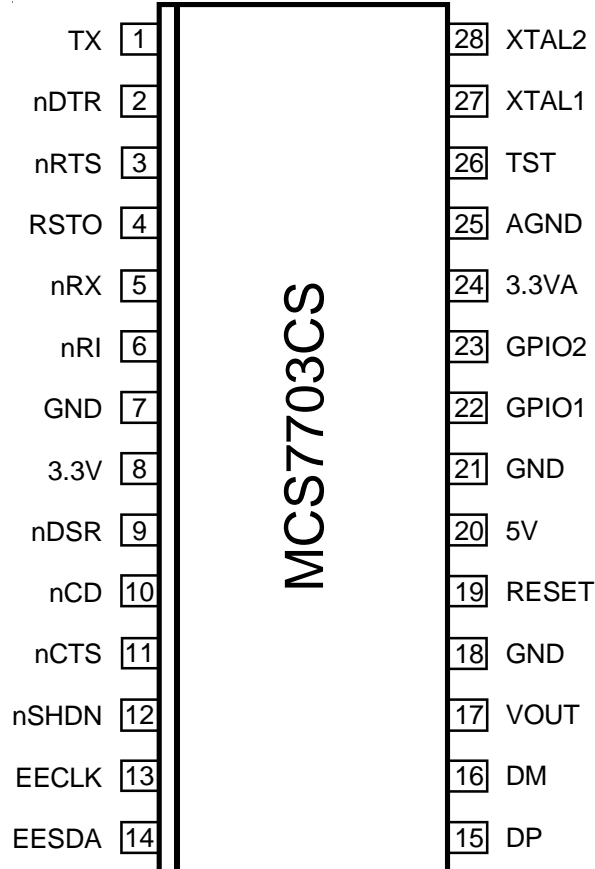

MCS7703

USB 1.1 to Serial Port



Pin Name	Pin	Type	Description
TX	1	O	Serial data output.
nDTR	2	O	Data-terminal-ready signal. It is set to high (inactive) after a hardware reset or during internal loop-back mode. When low, this output indicates to the modem or data set that the UART is ready to establish a communication link. nDTR has no effect on the transmitter or receiver.
nRTS	3	O	Request-to-send signal. It is set to high (inactive) after a hardware reset or during internal loop-back mode. When low, this indicates that modem or data set is ready to establish a communication link.
RSTO	4	O	Power On Reset output. Output of the internal Power on Reset is routed to this pin.
nRX	5	I	Serial data input.
nRI	6	I	Ring-detect signal.
nDSR	9	I	Data-set-ready signal.
nCD	10	I	Carrier-detect signal. When low this indicates that modem or data set has detected the data carrier. nCD has no effect on the transmitter.
nCTS	11	I	Clear-to-send signal. When low this indicates that modem or data set is ready to exchange data. nCTS has no effect on the transmitter.
nSHDN	12	O	Shut down External RS232 transceiver. Active low, when DCR2 Bit-7=0, Active high, when DCR2 bit-7=1. Default is active low.
EECLK	13	I/O	2 Wire EEPROM clock.
EESDA	14	I/O	2 Wire EEPROM data IN/OUT. Tri state.
DP	15	I/O	Upstream USB port differential data plus (D+), analog.
DM	16	I/O	Upstream USB port differential data minus (D-), analog.
VOUT	17	PWR	+3.3V Voltage regulator output.
RESET	19	I	System reset. Resets all internal registers, sequencers, and signals to a consistent state. Active high.
5V	20	PWR	Main power input. Connect to USB VBUS or local VDD.
GPIO1	22	I/O	If DCR0 bit-1=0, then GPIO is tri state after reset. When CR0 Bit-1=1, Bi-directional GPIO pin.
GPIO2	23	I/O	If DCR0 bit-1=0, at reset the state of this pin input is used to decide the load condition. Low is 100mA, high is 500mA. When DCR0 Bit-1=1, Bi-directional GPIO pin.
AGND	25	PWR	PLL Analog ground.
TST	26	I	Internal test mode (internal pull-up). When this pin is tied to 3.3V, the internal test mode is enabled. Low for normal operation.



Pin Name	Pin	Type	Description
XTAL1	27	I	Crystal oscillator or external clock input
XTAL2	28	O	Crystal oscillator output. See XTAL1 description.
GND	7, 18, 21	PWR	Power and signal ground.
3.3VA	24	PWR	Analog 3.3V Power supply
3.3V	8	PWR	Device supply input, to be connected to VOUT pin when 5V supply is used.

Note: All names with "n" prefix are active low.

MCS7703

USB 1.1 to Serial Port



Functional Description

The MCS7703 consists of two major functional blocks, the USB controller and the serial interface. The USB controller provides a Control, Bulk-In, and Bulk- Out endpoints to the USB host. The serial interface consists of a transmit and receive blocks that connect to external RS232 transceiver.

USB Interface

The USB interface to the host controller includes a Control endpoint, a Bulk-In end-point, and a Bulk-Out endpoint. The USB controller supports the USB 1.1 specification. Hence, it supports all standard functionality associated with device enumeration, standard USB device requests, etc. In addition, there is a set of vendor specific commands provided to allow a USB driver to access registers and ROM in the USB controller.

EEPROM Interface

The MCS7703 uses an optional external EEPROM to load vendor specific parameters. EEPROM is connected through a convenient 2 wire I2C interface.

After power on reset, the MCS7703 reads two bytes from the EEPROM. If the two bytes are equal to 9710 (hex) then it recognizes as an EEPROM being present and further 8 bytes are read. Else the MCS7703 reverts to default operating mode.

If EEPROM is present, following data will be loaded into the MCS7703 registers.

Byte2	Byte Length	Name	Description
1-0	2	EE Check	EEPROM Present check, 9710.
3-2	2	VID	Vendor ID (9710)
5-4	2	PID	Product ID (7703)
7-6	2	RN	Release Number in BCD format (0001)
10-8	3	DCR	Device Configuration Register (DCR)
12-11	2	Language ID	Language ID in Hex format (0409)
60-13	48	Manufacture ID	MosChip Semiconductor in UNICODE
102-61	42	Product Name	"USB-Serial controller" in UNICODE
118-103	16	Serial Number	"XXXXXXXX" in UNICODE



Device Configuration

Table below describes the function of each bit in the three registers. In the absence of the EEPROM the default values from the device configuration.

Register	Bit	Name	Description
DCR0	0	RS_SDM	RS232 Transceiver shut down mode: 0 = Normal operation 1 = Shut down the transceiver when USB Suspend is engaged (default).
DCR0	1	GPIO_1_Tri	GPIO1 pin state: 0 = Tri- Mode input (default). 1 = Assign as GPIO pin
DCR0	2-3	GPIO_Mode	(Default 00)
DCR0	4-5	RTS_CM	(Default 00)
DCR0	6	Mode Select	0 = RS232 Serial mode (default). 1 = Not used
DCR0	7	8/16 Mode	0 = Standard serial port (default). 1 = 16 bit Serial character mode.

MCS7703

USB 1.1 to Serial Port



Register	Bit	Name	Description
DCR1	0-1	GPIO_PMG	GPIO output current settings. 00 = 6mA 01 = 8mA (default) 10 = 10mA 11 = 12mA
DCR1	2-3	TX_PMG	Transmit output current settings. 00 = 6mA 01 = 8mA (default) 10 = 10mA 11 = 12mA
DCR1	4	Wakeup	Remote wakeup: 0 = Enable USB remote wakeup (default). 1 = Disable USB remote wakeup.
DCR1	5-7	RSVD	Reserved (Default=000)

Register	Bit	Name	Description
DCR2	0	WK_CTS	CTS wakeup function: 0 = Disabled (default). 1 = Wakeup will trigger on CTS state change
DCR2	1	WK_CD	CD wakeup function: CD wakeup function: 0 = Disabled (default). 1 = Wakeup will trigger on CD state change
DCR2	2	WK_RI	RI wakeup function: 0 = Disabled. 1 = Wakeup will trigger on RI state change (default).
DCR2	3	WK_DSR	DSR wakeup function: 0 = Disabled (default). 1 = Wakeup will trigger on RI state change
DCR2	4	WK_RX	RX wakeup function: 0 = Disabled (default). 1 = Wakeup will trigger on RI state change
DCR2	5	WK_RO	Remote wakeup function: 0 = Enable remote wakeup, disconnect signal. 1 = Wakeup, MCS7703 issues resume signal (default).
DCR2	6	RSTO	External RS232 three state control: 0 = Disabled (default). 1 = Enabled
DCR2	7	SHDN	nSHDN pin polarity: 0 = Active low nSHDN pin (default). 1 = Active high.

MCS7703

USB 1.1 to Serial Port



Absolute Maximum Ratings

Supply Range	6.0 Volts
Voltage at any pin	GND – 0.3 to VCC +0.3
Operating Temperature	-45° C to 90° C
Storage Temperature	-65° C to 150° C
Package Dissipation	500 mW
ESD	±2000 Volts
Latch up	220 mA

DC Electrical Specification

T = 0° C to 70° C, VCC = 3.3V – 5.0V ± 10% unless otherwise specified.

Symbol	Parameter	3.3V		5.0V		Unit	Condition
		Min	Max	Min	Max		
5.0V	Operating supply voltage			4.5	5.5	V	Voltage Regulator input supply
3.3V		3.0	3.6			V	
V _{icl}	Clock input low level clock	-0.5	0.6			V	External
V _{ihck}	Clock input high level clock	2.4	VCC			V	External
V _{il}	Input low level		1.08			V	CMOS
V _{ih}	Input high level	2.1				V	CMOS
V _{ol}	Output low level		0.4			V	I _{ol} = 6 mA
V _{oh}	Output high level	1.85				V	I _{oh} = 6 mA
I _{il}	Input leakage current	-10	+10			µA	
I _{cc}	Operating current	12	25		45	mA	
C _p	Input pin Capacitance		5		7	pF	

AC Electrical Specification

T = 0° C to 70° C, VCC = 3.3V - 5.0V ± 10% unless otherwise specified.

Symbol	Parameter	3.3V		5.0V		Unit	Condition
		Min	Max	Min	Max		
CLKA	USB clock frequency	12		12		MHz	+/- 50PPM

Revision	Notes	Date
1.1	Corrections	02/04
1.2	AC/DC characteristics	03/04
1.3	Pin name correction on the 28-Pin SSOP Package	03/04

MCS7703

USB 1.1 to Serial Port



28-Pin SSOP Package

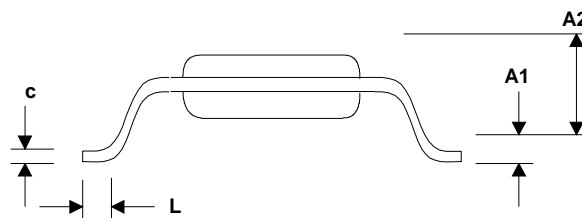
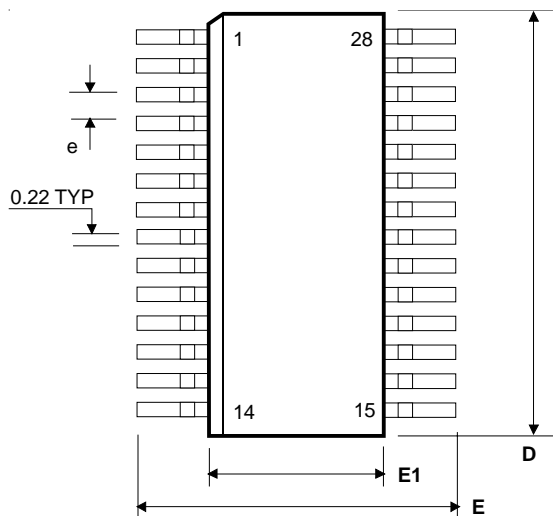

SYMBOL	MILLIMETERS		INCHES	
	MIN	MAX	MIN	MAX
A1	0.05	0.21	0.020	0.08
A2	1.65	1.80	0.650	0.708
e	0.65 TYP		0.026 TYP	
D	10.00	10.4	3.93	4.09
E1	5.2	5.4	2.05	2.12