

# BASIC Stamp<sup>®</sup> HomeWork Board<sup>™</sup> Project Platform

## #29158 10-pack

### Introduction

It's not often that we start technical documentation with a bit of marketing punch. If you like the low cost of a BASIC Stamp Rev. Dx (retails ~\$34) and the idea of a half-price BASIC Stamp 2 Microcontroller / Board of Education (retails ~\$100) then the BASIC Stamp HomeWork Board platform is the ticket for your class. This is the least expensive way to get a large educational group started with the BASIC Stamp 2 microcontroller.

These boards were created exclusively for educators to *send home with students* with these uses in mind:

- BASIC Stamp-related homework assignments
- Dedicated science-fair, contest or hobby projects
- Students who express personal interest in further developing their BASIC Stamp projects but can't have their own Board of Education / BS2 due to its higher cost

Since its less expensive than the Board of Education / BS2 module, can the board be used for Stamps in Class experiments? Possibly, with the following considerations:

- Servo connection ports for robotics are not included on the HomeWork Board platform. It's possible to use male/male headers for servo connections with a second power supply jumpered to the HomeWork Board platform to control servos.
- 220 ohm resistors are built into each of the 16 I/O pins for current protection so the PBASIC interpreter cannot be easily damaged. This protects the BASIC Stamp from over-current conditions but also slightly changes the behavior of the Stamps in Class experiments if used on this board, depending on the command being used.
- Some Stamps in Class circuit pictorials may not support the HomeWork Board platform. Again, this needs only a minor workaround once you understand the difference between the power supply options.
- Power supply is from a 9V battery, not the wall pack.
- Current supply from the on-board regulator is limited to 500 mA (Rev C) versus the Board of Education's amp or more.

However, these cost-reducing limitations do not limit the use of the HomeWork Board platform for other projects. In fact, the minimalist design is simple to use and entirely flexible for most projects.

## Package Contents

The BASIC Stamp HomeWork Board is sold only in quantities of 10. The reason for this is that the board is intended for the educational market only, to be purchased by educators for use in their classrooms. The kit includes only the boards – nothing else.

## BASIC Stamp HomeWork Board Hardware Design

The BASIC Stamp HomeWork Board platform uses the BASIC Stamp 2 microcontroller surface-mounted directly to the printed circuit board. The BASIC Stamp 2 microcontroller has a wide variety of available support hardware, code examples and applications. Further, it performs most of the same functions of the newer BASIC Stamp models, though with less speed and memory. Its technical specifications are shown below (Table 1). Also review the hardware (Figure 1) and schematic (Figure 2).

Table 1		
BASIC Stamp HomeWork Board Specifications.	Microcontroller:	PIC16C57 surface mount
	Speed:	20 MHz / ~4,000 instructions per second
	EEPROM:	2K bytes (program and data)
	Program Length:	500 lines of PBASIC
	RAM (variables):	32 bytes (6 for I/Os and 26 for variables)
	Input / Outputs:	16 (up to 17 RS-232 communication ports)
	On-board BS2 per I/O Source/Sink current	20 / 25 mA (40 / 50 mA per 8 I/O pins)
	Vdd Source Current (Rev A and B)	50 mA
	Vdd Source Current: (Rev C)	500 mA
	Serial Communication:	300-50K baud I/O
	Current Requirements:	7 mA running, 50 uA in sleep
	PC Interface:	Serial port
	Power Supply:	5 V through an LM2936 regulator from a 9V transistor battery
	Environment:	32 to 158° F (0 to 70° C), 70% non-condensing humidity
	Dimensions:	3" x 4"
	Project Area:	Built-in breadboard
Microcontroller:	PIC16C57 surface mount	
Speed:	20 MHz / about 4,000 instructions per second	
EEPROM:	2K bytes (program and data)	
Program Length:	~500 to 600 lines of PBASIC	

Figure 1

HomeWork Board (Rev A and B) printed circuit board keyed with part identifications.

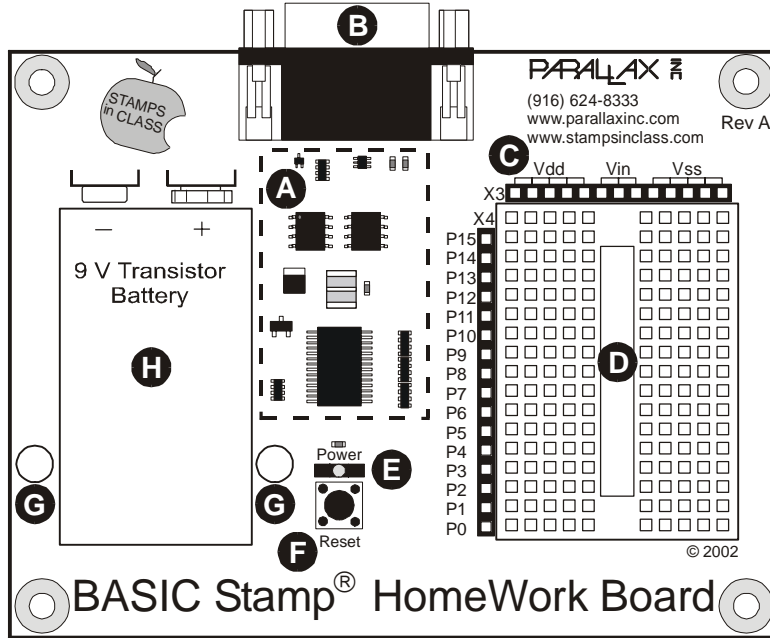
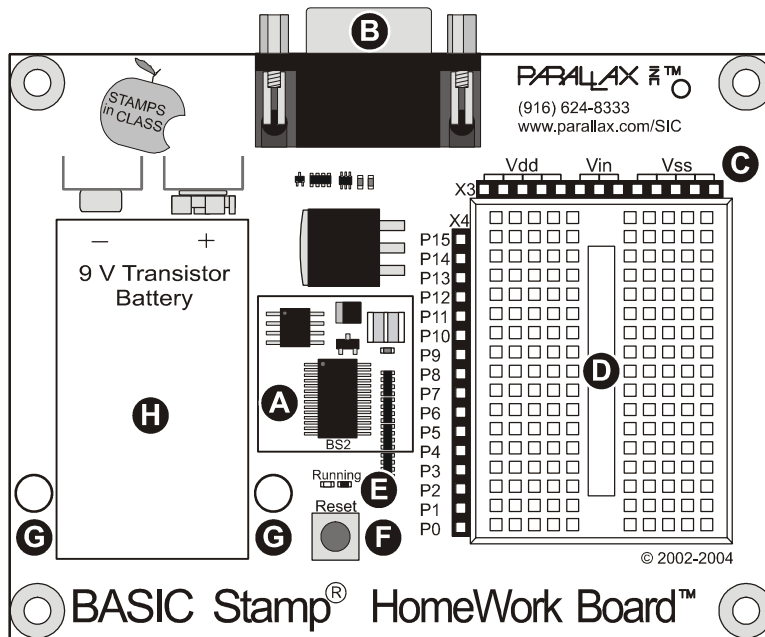

Figure 2

HomeWork Board (Rev C) printed circuit board keyed with part identifications.



- A. **BASIC Stamp 2 Module.** The BASIC Stamp microcontroller is comprised of several components: PIC16C57-20/SS - a Microchip 2K 8-bit microcontroller programmed with the BASIC Stamp "Interpreter" that runs the Parallax BASIC Stamp code like a mini operating system; the 24LC16B EEPROM - a Microchip 2K EEPROM (electrically erasable programmable read-only memory) with a user-modifiable read-only memory (ROM) that can be reprogrammed with your BASIC Stamp code; a 20 MHz resonator to provide an accurate clock source for the BASIC Stamp. In this board we also added 220  $\Omega$  resistors across the I/O pins to provide current protection for mistake wiring and a bigger voltage regulator (Rev C) which provides 500 mA for the BASIC Stamp and your circuits powered from the breadboard's Vdd connection.

- B. DB-9 Female.** The DB-9 port connects via serial cable to your PC's serial port. This port is used to download programs to your BASIC Stamp and for the BASIC Stamp to send data back to the PC.
- C. Power and Ground Connections.** Vdd is regulated 5V, Vin is 9V from the transistor battery, Vss is ground.
- D. Breadboard.** Two areas of 5 column x 17 row breadboard project area. Connections are horizontal separated by the trough.
- E. Running Indicator.** Illuminated when the BASIC Stamp microcontroller is running a program only.
- F. Reset Circuit.** Reset the BASIC Stamp by pressing this button.
- G. Battery Tie-Downs.** If using the HomeWork Board for projects involving high-vibration (on R/C airplanes, robots, etc.) a "zip-tie" can hold the battery firmly to the board if looped through these holes.
- H. Power Supply.** Accepts a 9V battery.

Figure 2

BASIC Stamp HomeWork Board Schematic (all revisions)

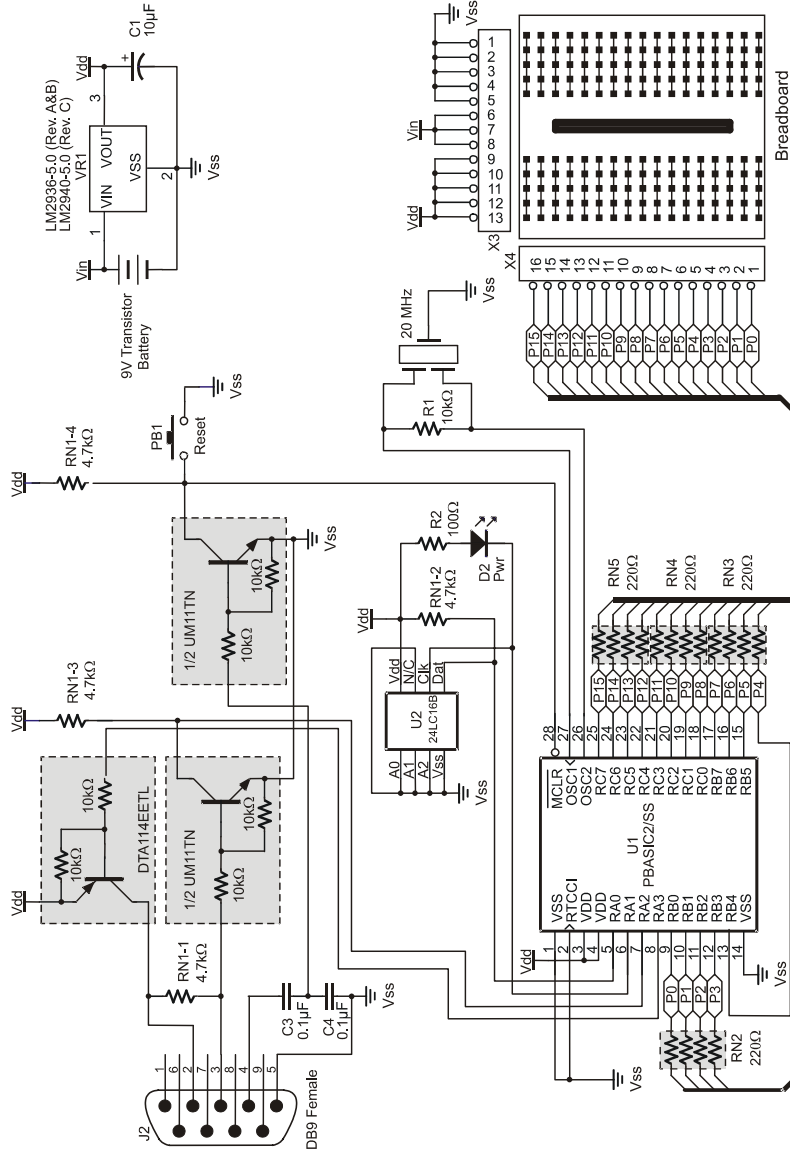

### Power Consumption and Battery Life

Parallax normally designs BASIC Stamp carrier boards with power jacks for wall transformers. Wall transformers provide plenty of power but they are not as portable for science fairs, robots and environmental datalogging. Considering that the BASIC Stamp draws only small amounts of current it could be deployed in a remote location and run from a battery for a long time.

The BASIC Stamp has commands for reduced power consumption, but what about the power indicator LED? It could drain the battery in a day or two by itself if being used to indicate a power supply! LEDs consume current, typically 10-12 mA. Removing the LED wasn't an option since it discloses the common technical support problem of a missing power supply.

The solution was to connect BASIC Stamp HomeWork Board's power LED to the "clock" line of the BASIC Stamp's EEPROM. The EEPROM's clock line is active only when the BASIC Stamp is actually running a

program. Moreover, the BASIC Stamp HomeWork Board's power LED is a low current LED consuming only about 2 mA.



MilliAmp hours is a statistic measuring the amount of energy stored in a battery. For example, if you have a 1 mA-hr battery and a project drawing 0.5 milliamps, the battery will last for two hours. A typical 9V alkaline transistor battery provides about 565 milliAmp hours of energy.

If the BASIC Stamp is being used in a project where at least *some* small amount of time is spent doing nothing you can put it in a low-power mode to extend battery life using the SLEEP command (Table 2). The duration which you put the BASIC Stamp to SLEEP is accurate to  $\pm 1\%$  at 75° F and can range from 2.3 seconds to 18 hours (you can “wake up” and go back to sleep after 18 hours). By comparison, the PAUSE command is simply a delay in a PBASIC program yet the BASIC Stamp continues to draw full operating current. See the BASIC Stamp Windows Editor on-line help for all the details on the SLEEP and PAUSE commands.

Table 2		BASIC Stamp Current Draw	Power LED Current Draw	Possible Battery Life
BASIC Stamp 2 and Power LED current draw during different modes of operation.	PAUSE Mode	8 mA	2 mA	(565 mAh/10 mA) = 56.5 hours
	SLEEP Mode	40 $\mu$ A	0 mA	(565 mAh/(40 $\mu$ A/1000 mA)) = 14,125 hours

Note: 1 mA is 1/1,000<sup>th</sup> of an Amp. 1 microAmp ( $\mu$ A) is 1/10,000<sup>th</sup> of an Amp.

Maybe putting a BASIC Stamp to SLEEP permanently only demonstrates that a 9V battery can last almost two years if you wake the BASIC Stamp once in a while. In reality, projects need to wake up and provide current to “loads” like LEDs and other chips used in your project. If you know the current draw of the individual components and how long they are activated you can make an educated guess at total current consumption and battery life. If you're only visiting your North Pole weather station annually even a small battery can provide a long lifespan for the BASIC Stamp, not to mention larger batteries with more milliamp hours.

To clarify different BASIC Stamp power consumption operating scenarios and their effects on battery life review the following two programs in conjunction with Table 2.

Both programs have the same result. The BASIC Stamp will send numbers to the BASIC Stamp Windows Editor debug window and then go into a period of inactivity for a second. With the PAUSE example the power LED remains on because the EEPROM is still communicating with the BASIC Stamp interpreter chip, but with the SLEEP example the EEPROM is shut down and the power LED is off.

With this example the Power LED remains on when the PAUSE command is executed. Current consumption remains at 10 mA.

```
' POWER DEMO - PAUSE.BS2
' Demonstrating the power LED with SLEEP command
' {$STAMP BS2}
' {$PBASIC 2.5}

' I/Os, Constants and Variable definitions
loopCounter VAR Byte

' Main Program
DO
  FOR loopCounter = 0 TO 99
    DEBUG HOME, "loopCounter =", DEC loopCounter
  NEXT
```

```
PAUSE 1000
LOOP
```

With the SLEEP example the Power LED turns off when the SLEEP command is being executed because the EEPROM is inactive. Current consumption is 10 mA while the loop is being executed but drops to 40  $\mu$ A during the SLEEP command.

```
' POWER DEMO - SLEEP.BS2
' Demonstrating the power LED with SLEEP command STEve
' {$STAMP BS2}
' {$PBASIC 2.5}

' I/Os, Constants and Variable definitions
loopCounter VAR Byte

' Main Program
DO
  FOR loopCounter = 0 TO 99
    DEBUG HOME, "loopCounter =", DEC loopCounter
  NEXT
  SLEEP 1
LOOP
```

## Precautions

Be alert to static sensitive devices and static-prone situations. The BASIC Stamp Microcontroller, like other integrated circuits, can be damaged by static discharge that commonly occurs by touching grounded surfaces or other conductors. Environmental conditions (humidity changes, wind, static prone surfaces, etc) play a major role in the presence of random static charges. It is always recommended to use grounding straps and anti-static or static dissipative mats when handling devices like the BASIC Stamp. If you don't have a dissipative mat, touch a grounded surface after you have approached your work area.

Before building or modifying circuits, disconnect the battery.

## Setup information

You can find a quick start guide about connecting the HomeWork Board to the PC and programming it in the first two chapters of the Stamps in Class book "*What's a Microcontroller?*," available as free download in our website [www.parallax.com/sic](http://www.parallax.com/sic).